**High efficiency filters and filter media
for removing particles from air —**

Part 1:
**Classification, performance, testing
and marking**

*Filtres et media à très haute efficacité pour la rétention
particulaire —*

Partie 1: Classification, essais de performance et marquage





COPYRIGHT PROTECTED DOCUMENT

© ISO 2017, Published in Switzerland

All rights reserved. Unless otherwise specified, no part of this publication may be reproduced or utilized otherwise in any form or by any means, electronic or mechanical, including photocopying, or posting on the internet or an intranet, without prior written permission. Permission can be requested from either ISO at the address below or ISO's member body in the country of the requester.

ISO copyright office
Ch. de Blandonnet 8 • CP 401
CH-1214 Vernier, Geneva, Switzerland
Tel. +41 22 749 01 11
Fax +41 22 749 09 47
copyright@iso.org
www.iso.org

Contents

Page

Foreword	iv
Introduction	v
1 Scope	1
2 Normative references	1
3 Terms and definitions	1
4 Symbols and abbreviated terms	3
5 Classification	3
6 Requirements	4
6.1 General	4
6.2 Material	4
6.3 Nominal air volume flow rate	5
6.4 Pressure difference	5
6.5 Filtration performance	5
7 Test methods — General requirements and test procedures overview	5
7.1 General	5
7.2 Test rigs	5
7.3 Test conditions	5
7.4 Test aerosols	6
7.5 Test methods — Principles	6
7.5.1 Test method for flat sheet filter media	6
7.5.2 Test method for determining the leakage of filter elements — Scan method	9
7.5.3 Test method for determining the efficiency of filter elements	10
7.5.4 Remarks	11
8 Assessment of the filter, documentation, test reports	12
9 Marking	12
Annex A (informative) Filtration of nanoparticles	13
Annex B (informative) Summary of classification and test methods	14
Bibliography	16

Foreword

ISO (the International Organization for Standardization) is a worldwide federation of national standards bodies (ISO member bodies). The work of preparing International Standards is normally carried out through ISO technical committees. Each member body interested in a subject for which a technical committee has been established has the right to be represented on that committee. International organizations, governmental and non-governmental, in liaison with ISO, also take part in the work. ISO collaborates closely with the International Electrotechnical Commission (IEC) on all matters of electrotechnical standardization.

The procedures used to develop this document and those intended for its further maintenance are described in the ISO/IEC Directives, Part 1. In particular, the different approval criteria needed for the different types of ISO documents should be noted. This document was drafted in accordance with the editorial rules of the ISO/IEC Directives, Part 2 (see www.iso.org/directives).

Attention is drawn to the possibility that some of the elements of this document may be the subject of patent rights. ISO shall not be held responsible for identifying any or all such patent rights. Details of any patent rights identified during the development of the document will be in the Introduction and/or on the ISO list of patent declarations received (see www.iso.org/patents).

Any trade name used in this document is information given for the convenience of users and does not constitute an endorsement.

For an explanation on the voluntary nature of standards, the meaning of ISO specific terms and expressions related to conformity assessment, as well as information about ISO's adherence to the World Trade Organization (WTO) principles in the Technical Barriers to Trade (TBT), see the following URL: www.iso.org/iso/foreword.html.

This document was prepared by Technical Committee ISO/TC 142, *Cleaning equipment for air and other gases*.

This second edition cancels and replaces the first edition (ISO 29463-1:2011), which has been technically revised.

This edition includes the following significant changes with respect to the previous edition:

- [Table 1](#) has been split into two tables;
- a definition for "particle diameter" has been added;
- it has been stated that the filter test certificate shall clearly indicate if the filter has been tested without seal fitted.

A list of all parts in the ISO 29463 series can be found on the ISO website.

Introduction

ISO 29463 (all parts) is derived from EN 1822 (all parts). It contains requirements, fundamental principles of testing and the marking for, high-efficiency particulate air filters with efficiencies from 95% to 99,999 995% that can be used for classifying filters in general or for specific use by agreement between users and suppliers.

ISO 29463 (all parts) establishes a procedure for the determination of the efficiency of all filters on the basis of a particle counting method using a liquid (or alternatively a solid) test aerosol, and allows a standardized classification of these filters in terms of their efficiency, both local and overall efficiency, which actually covers most needs of different applications. The difference between this document and other national standards lies in the technique used for the determination of the overall efficiency. Instead of mass relationships or total concentrations, this technique is based on particle counting at the most penetrating particle size (MPPS), which is for micro-glass filter mediums usually in the range of 0,12 μm to 0,25 μm . This method also allows testing ultra-low penetration air filters, which was not possible with the previous test methods because of their inadequate sensitivity. For membrane filter media, separate rules apply, and are described in ISO 29463-5:2011, Annex B. Although no equivalent test procedures for testing filters with charged media is prescribed, a method for dealing with these types of filters is described in ISO 29463-5:2011, Annex C. Specific requirements for testing method, frequency, and reporting requirements may be modified by agreement between supplier and customer. For lower efficiency filters (Group H, as described in [Clause 5](#)), alternate leak test methods noted in ISO 29463-4:2011, Annex A may be used by specific agreement between users and suppliers, but only if the use of these other methods is clearly designated in the filter markings, as noted in the annex. Although the methods prescribed in this document may be generally used to determine filter performance for nano-size particles, testing or classification of filters for nano-size particles are beyond the scope of this document (see [Annex A](#) for additional information).

There are differences between ISO 29463 (all parts) and other normative practices common in several countries. For example, many of these rely on total aerosol concentrations rather than individual particles. A brief summary of these methods and their reference standards is provided in ISO 29463-5:2011, Annex A.

High efficiency filters and filter media for removing particles from air —

Part 1: Classification, performance, testing and marking

1 Scope

This document establishes a classification of filters based on their performance, as determined in accordance with ISO 29463-3, ISO 29463-4 and ISO 29463-5. It also provides an overview of the test procedures, and specifies general requirements for assessing and marking the filters, as well as for documenting the test results. It is intended to be used in conjunction with ISO 29463-2, ISO 29463-3, ISO 29463-4 and ISO 29463-5.

2 Normative references

The following documents are referred to in the text in such a way that some or all of their content constitutes requirements of this document. For dated references, only the edition cited applies. For undated references, the latest edition of the referenced document (including any amendments) applies.

ISO 29463-2:2011, *High-efficiency filters and filter media for removing particles in air — Part 2: Aerosol production, measuring equipment and particle-counting statistics*

ISO 29463-3:2011, *High-efficiency filters and filter media for removing particles in air — Part 3: Testing flat sheet filter media*

ISO 29463-4:2011, *High-efficiency filters and filter media for removing particles in air — Part 4: Test method for determining leakage of filter elements-Scan method*

ISO 29463-5:2011, *High-efficiency filters and filter media for removing particles in air — Part 5: Test method for filter elements*

ISO 29464:2017, *Cleaning equipment for air and other gases — Terminology*

3 Terms and definitions

For the purposes of this document, the terms and definitions given in ISO 29464 and the following apply.

ISO and IEC maintain terminological databases for use in standardization at the following addresses:

- IEC Electropedia: available at <http://www.electropedia.org/>
- ISO Online browsing platform: available at <http://www.iso.org/obp>

3.1

filter medium

material used for filtering

3.2

folded pack

pack of the *filter medium* (3.1) formed by uniform individual folds

3.3
filter element
filter

folded pack (3.2) enclosed by a frame

3.4
efficiency

ratio of the number of particles retained by the filter to the number of the particles entering it

3.5
particle size efficiency

efficiency (3.4) for a specific *particle diameter* (3.6)

Note 1 to entry: The efficiency plotted as a function of the particle diameter gives the fractional efficiency curve.

3.6
particle diameter

geometric diameter (equivalent spherical, optical or aerodynamic, depending on context) of the particles of an aerosol

Note 1 to entry: Particle diameter is often referred to simply as "particle size".

[SOURCE: ISO 29464:2017, 3.2.124]

3.7
overall efficiency

efficiency (3.4), averaged over the whole *superficial face area* (3.11) of a *filter element* (3.3) under given operating conditions of the filter

3.8
local efficiency

efficiency (3.4) at a specific point of the *filter element* (3.3) under given operating conditions of the filter

3.9
nominal air volume flow rate

air volume flow rate at which the *filter element* (3.3) shall be tested as specified by the manufacturer

3.10
filter face area

cross-sectional area of the *filter element* (3.3) including the frame

3.11
superficial face area

cross-sectional area of the *filter element* (3.3) through which the air flow passed

3.12
effective filter medium area

area of the *filter medium* (3.1) contained in the *filter element* (3.3) (without areas covered by sealant, spacers, struts, etc.) which the air flow passes

3.13
nominal filter medium face velocity

nominal air volume flow rate (3.9) divided by the effective *filter medium* (3.1) area

3.14
quasi-monodisperse aerosol

aerosols whose distribution has a geometric standard deviation between $\sigma_g = 1,15$ and $\sigma_g = 1,5$

4 Symbols and abbreviated terms

d_p	particle diameter
E	efficiency
P	penetration
p	pressure
σ_g	geometric standard deviation
CPC	condensation particle counter
DEHS	Sebacic acid-bis (2 ethyl hexyl-) ester (trivial name: di-ethyl-hexyl-sebacate)
DMA	differential electric mobility analyser
DMPS	differential mobility particle sizer
MPPS	most penetrating particle size, that is the particle size for which the filtration efficiency is a minimum
OPC	optical particle counter
PAO	poly-alpha-olefin, mineral oil with Chemical Abstract Service Registry number of 68649-12-7
PSL	poly-styrene latex (solid spheres)

5 Classification

Filters and filter elements are classified in groups and classes based on their efficiency or penetration for the MPPS particles by testing as prescribed in [Clause 6](#) and in ISO 29463-5. According to this document, filter elements fall into one of the following groups.

- a) Group E: EPA filters (efficient particulate air filter), also commonly referred to as sub-HEPA.
The efficiency of the filters is determined by statistical sample testing only in accordance with ISO 29463-5. Group E filters cannot and shall not be leak tested.
- b) Group H: HEPA filters (high-efficiency particle air filter)
Filters are individually tested and their efficiency is determined at MPPS in accordance with ISO 29463-5. The filter is leak tested in accordance with ISO 29463-4, where, in addition to the reference leak scan method, four alternate methods for leak testing are allowed. Alternate norms used for leak testing should be clearly identified on the filter and certifications.
- c) Group U: ULPA filters (ultra-low penetration air filter)
Filters are individually tested and their efficiency is determined at MPPS in accordance with ISO 29463-5. Filters are leak tested according to scan method in accordance with ISO 29463-4. No alternate leak testing is allowed.

A detailed specification for each filter group and class is given in [Tables 1](#) and [2](#). Either of them can be used for filter classification purposes.

Detailed information about the permissible test methods in accordance with ISO 29463 (all parts) for each filter group and class of filters is given in [Table B.1](#).

Table 1 — Filter classification: Allowed filter classes (5/10th filter efficiency)

Filter class and group	Overall value		Local value ^{a,b}	
	Efficiency (%)	Penetration (%)	Efficiency (%)	Penetration (%)
ISO 15 E	≥95	≤5	— ^c	— ^c
ISO 25 E	≥99,5	≤0,5	— ^c	— ^c
ISO 35 H ^d	≥99,95	≤0,05	≥99,75	≤0,25
ISO 45 H ^d	≥99,995	≤0,005	≥99,975	≤0,025
ISO 55 U	≥99,999 5	≤0,000 5	≥99,997 5	≤0,002 5
ISO 65 U	≥99,999 95	≤0,000 05	≥99,999 75	≤0,000 25
ISO 75 U	≥99,999 995	≤0,000 005	≥99,999 9	≤0,000 1

^a See 7.5.2.4 and ISO 29463-4.

^b Local penetration values lower than those given in this table may be agreed upon between the supplier and customer.

^c Filters of Group E cannot and shall not be leak tested for classification purposes.

^d For Group H filters, local penetration is given for reference MPPS particle scanning method. Alternate limits may be specified when photometer or oil thread leak testing is used.

Table 2 — Filter classification: Allowed filter classes (1/10th filter efficiency)

Filter class and group	Overall value		Local value ^{a,b}	
	Efficiency (%)	Penetration (%)	Efficiency (%)	Penetration (%)
ISO 20 E	≥99	≤1	— ^c	— ^c
ISO 30 E	≥99,90	≤0,1	— ^c	— ^c
ISO 40 H ^d	≥99,99	≤0,01	≥99,95	≤0,05
ISO 50 U	≥99,999	≤0,001	≥99,995	≤0,005
ISO 60 U	≥99,999 9	≤0,000 1	≥99,999 5	≤0,000 5
ISO 70 U	≥99,999 99	≤0,000 01	≥99,999 9	≤0,000 1

^a See 7.5.2.4 and ISO 29463-4.

^b Local penetration values lower than those given in this table may be agreed upon between the supplier and customer.

^c Filters of Group E cannot and shall not be leak tested for classification purposes.

^d For Group H filters, local penetration is given for reference MPPS particle scanning method. Alternate limits may be specified when photometer or oil thread leak testing is used.

6 Requirements

6.1 General

The filter element shall be designed or marked so as to prevent incorrect mounting.

The filter element shall be designed so that when correctly mounted in the ventilation duct, no leak occurs along the sealing edge.

If, for any reason, dimensions do not allow testing of a filter under standard test conditions, assembly of two or more filters of the same type or model is permitted, provided no leaks occur in the resulting filter.

If the filter is tested without the filter seal fitted, and if designed to have a filter seal, then the filter test certificate shall be clearly marked “filter efficiency tested without filter seal fitted”.

6.2 Material

The filter element shall be made of suitable material to withstand normal usage and exposures to those temperatures, humidity and corrosive environments that are likely to be encountered.

The filter element shall be designed so that it will withstand mechanical constraints that are likely to be encountered during normal use.

Dust or fibres released from the filter media by the air flow through the filter element shall not constitute a hazard or nuisance for the people (or devices) exposed to filtered air.

6.3 Nominal air volume flow rate

The filter element shall be tested at its nominal air volume flow rate for which the filter has been designed by the manufacturer.

6.4 Pressure difference

The pressure difference across the filter element is recorded at the nominal air volume flow rate.

6.5 Filtration performance

The filtration performance is expressed by the efficiency or the penetration as measured by the prescribed procedures in ISO 29463-5. After testing in accordance with [Clause 7](#), filter elements are classified in accordance with [Tables 1](#) and [2](#).

Filters with filter media having an electrostatic charge are classified in accordance with [Tables 1](#) and [2](#), on the basis of their discharged efficiency or penetration in accordance with ISO 29463-5:2011, Annex C.

7 Test methods — General requirements and test procedures overview

7.1 General

The complete test method comprises the following three steps, which can be performed independently:

- test for flat sheet filter media, in accordance with ISO 29463-3;
- test for determining the leakage of filter elements (scan method), in accordance with ISO 29463-4;
- test for determining the efficiency of filters, in accordance with ISO 29463-5.

[Clause 7](#) provides the general requirements for the features common to all tests, as well as an overview of the test procedures.

Detailed information about the permissible test methods for filter elements in accordance with ISO 29463 (all parts) for each filter group and class of filters is given in [Table B.1](#).

7.2 Test rigs

Test rigs shall be in accordance with ISO 29463-3, ISO 29463-4 and ISO 29463-5 for the respective tests. The measuring equipment shall be in accordance with ISO 29463-2.

7.3 Test conditions

The air in the test channel used for testing shall comply with the following requirements:

- temperature: $23\text{ °C} \pm 5\text{ °C}$;
- relative humidity $<75\%$.

The temperature shall remain constant during the entire test procedure within $\pm 2\text{ °C}$, the relative humidity within $\pm 5\%$.

The cleanliness of the test air shall be ensured by appropriate pre-filtering, so that in operation without addition of aerosol the particle number concentration measured with the particle counting method is less than 352 000 particles/m³. The test specimen shall have the same temperature as the test air and hence shall be conditioned at test requirements (temperature and relative humidity) long enough to be in equilibrium.

7.4 Test aerosols

For the testing of filters in accordance with this document, a liquid test aerosol shall be used as the reference test method. Alternatively, a solid aerosol may be used for leak testing (see ISO 29463-4:2011, Annex E). Possible aerosol substances include, but are not limited to, DEHS, PAO and PSL. For further details, see ISO 29463-2:2011, 4.1.

The use of alternative materials for challenge aerosols shall be agreed between supplier and customer when the materials specified in this document are unacceptable.

The concentration and the size distribution of the aerosol shall be constant, within experimental limits, over time. Details of aerosol generation for testing is addressed in the other parts of ISO 29463. For the leak test and the efficiency test of the filter element, the count mean particle diameter of the test aerosol shall correspond to the most penetrating particle size (MPPS) for the filter medium.

7.5 Test methods — Principles

7.5.1 Test method for flat sheet filter media

7.5.1.1 General

The fractional efficiency curve of flat sheet filter medium samples is determined in new condition (material as supplied by the medium manufacturer) and in discharged condition (see ISO 29463-5:2011, Annex C). If these measurements reveal that the filter medium is having a significant charge, the filter elements shall be classified on the basis of the discharged flat sheet efficiency or penetration measurements in accordance with ISO 29463-5:2011, Annex C.

From the fractional efficiency curve generated this way, the most penetrating particle size (MPPS) shall be determined.

7.5.1.2 Test samples

The testing procedure requires at least five flat sheet samples of the filter material that will make up the filter elements.

The test samples shall be free of folds, creases, holes and other irregularities. The test samples shall have a minimum size of 200 mm × 200 mm.

7.5.1.3 Test apparatus

The arrangement of the test apparatus is shown in [Figure 1](#). The test rig is described in detail in ISO 29463-3. The individual measuring instruments and other devices are described in ISO 29463-2. An aerosol is produced in the aerosol generator, then passed through a conditioner (for example, to evaporate a solvent) and neutralised, before being brought together with the particle-free mixing air to the test filter medium mounting assembly.

Sampling points are positioned upstream and downstream from the test filter medium mounting assembly from which a part of the flow is led to the particle counter. The upstream sampling point is connected with a known ratio dilution circuit to reduce the high particle concentration down to the actual measuring range of the particle counter.

When using the total count counting method (CPC), a differential electric mobility analyser (DMA) is included before the aerosol neutralizer to separate out a quasi-monodisperse fraction of the required particle size from the initial polydisperse aerosol.

If a counting method with particle size analysis (OPC) is used, the size distribution of a polydisperse aerosol can be measured before and after the test specimen.

Instead of using a single particle counter, which measures the unfiltered and filtered air consecutively, it is also permissible to use two particle counters of equal optical design (wavelength of light source, light scattering angle, etc.) simultaneously for both measurements. When using two particle counters, the two counters shall be correlated by measuring the same aerosol to correct for any response differences." It is known that OPCs of the same model can give different responses.

After the downstream sampling point, the test aerosol is led through an exhaust filter and extracted by a pump. The apparatus is completed by devices to measure (and regulate) the air volume flow rate and the differential pressure across the filter under test.

The measurement data is recorded and evaluated by a computer.

The test apparatus can also be operated in an overpressure mode. In this case, the extraction pump is not required and the mixing air is supplied from a compressed air line. If so desired, the measurement and regulation of the air volume flow rate can then be carried out on the upstream side.

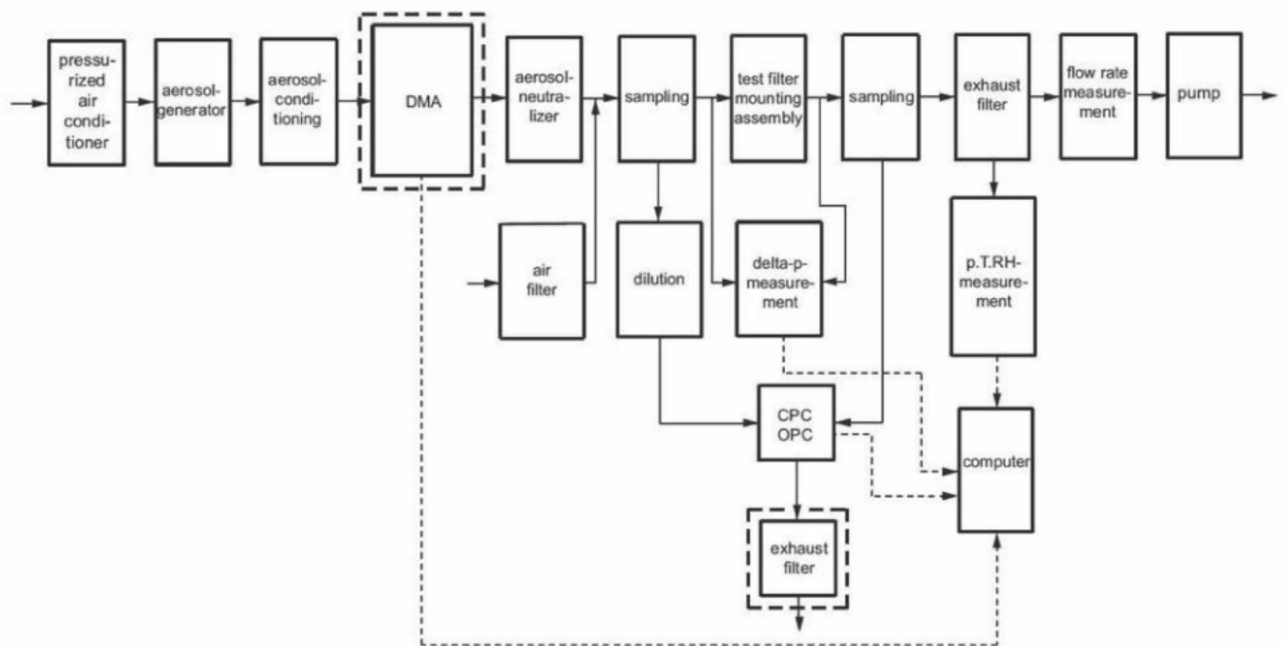

Figure 1 — Arrangement of apparatus for testing the filter medium

7.5.1.4 Measurement procedure

The performance of the filter medium is determined by testing a circular sample with an exposed area of 100 cm² at the nominal filter medium face velocity. Details of the measurements are described in ISO 29463-3. In order to establish the penetration versus particle size curve, the penetration values for at least six logarithmically, approximately equidistant particle size points are determined.

For this measurement, quasi-monodisperse test aerosol from a DMA with appropriate median values of the particle diameter is used, and their concentrations determined upstream and downstream of the test sample. Alternately, the size distribution of a polydisperse aerosol may be determined by OPC's upstream and downstream of the test sample in at least six particle size classes. In each case, it shall

be ensured that the measuring range of the particle counter and the range of produced particle sizes envelopes the minimum of the efficiency curve (MPPS).

7.5.1.5 Evaluation of test results

From the measurements on the five test samples, the efficiency versus particle size curve shall be drawn (see [Figure 2](#) for an example) from which the position and value of the minimum efficiency shall be determined.

Arithmetic mean values shall be determined for

- the minimum efficiency,
- the particle size at the minimum efficiency (MPPS), and
- the pressure difference, i.e., resistance.

The particle size at the MPPS shall subsequently be used as the mean size of the test aerosol in the filter element leakage test (see [7.5.2](#)) and in the efficiency test (see [7.5.3](#)).

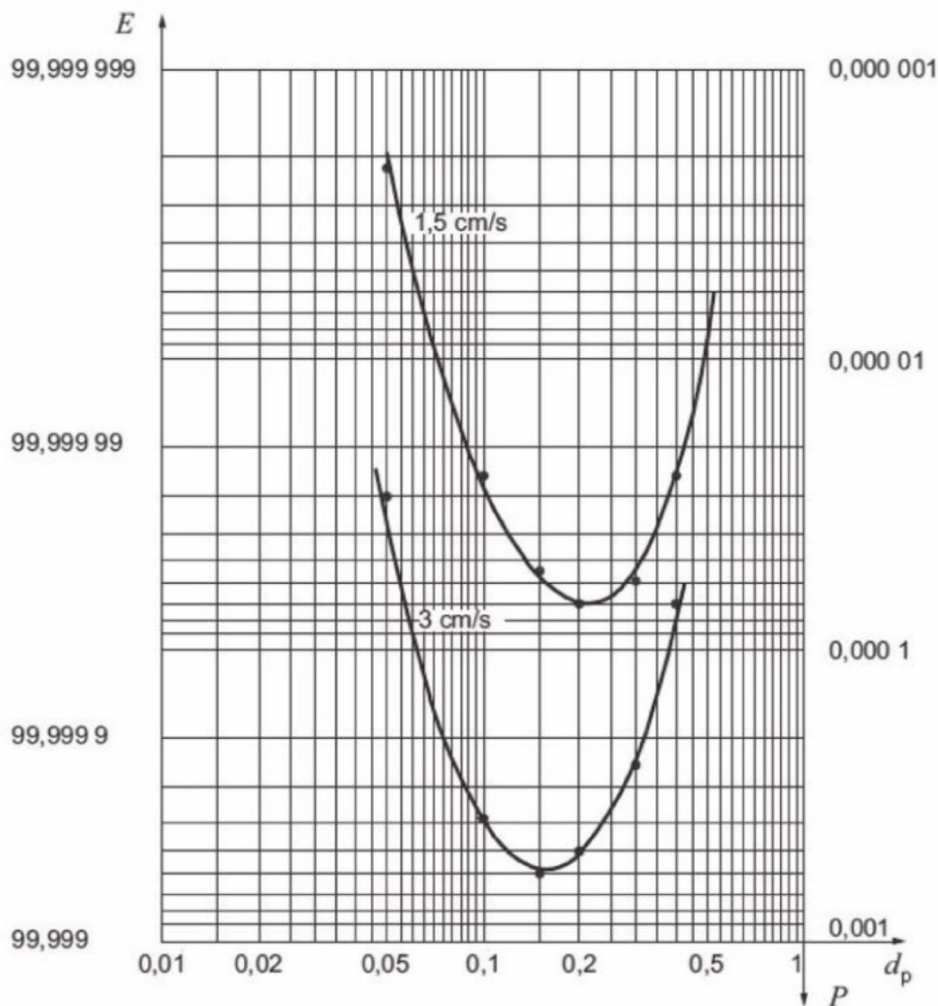

Figure 2 — Particle size efficiency, E , and penetration, P , of an ULPA-filter medium as function of the particle diameter, d_p , for two different filter medium velocities — Example

7.5.2 Test method for determining the leakage of filter elements — Scan method

7.5.2.1 General

The leak test serves to test the filter elements of groups H and U for local penetration and the absence of leaks, respectively (see [Tables 1](#) and [2](#)). The reference method and basis for this test is the particle counting scan method as described in ISO 29463-4.

Filter elements of Group H shall be leak tested using one of the five leak test methods described in ISO 29463-4:2011; the reference scanning method, the oil thread leak test, the aerosol photometer filter scan leak test, the PSL Leak Test, or the 0,3 µm to 0,5 µm particle efficiency leak test (ISO 29463-4:2011, Annexes A, B, E and F). Group U filters shall be leak tested using the MPPS scanning method only, in accordance with ISO 29463-4. All leak tests must be performed at the nominal/rated air flow of the tested filter element.

For Group H filters with filter shapes creating highly turbulent air flow (e.g. V-bank or cylindrical filters), for which the reference scan method cannot be applied, leak testing by either of the two alternative methods may be applied; the oil thread leak test (ISO 29463-4:2011, Annex A) or the 0,3 µm to 0,5 µm particle efficiency leak test (ISO 29463-4:2011, Annex F). For Group U filters with similar construction (e.g. V-bank or cylindrical filters), the alternative methods might not be sensitive enough to measure the local penetration limits specified in [Table 1](#). Therefore, Group U filters, leak tested with the alternative methods have to be marked “Alternative leak tested, method A or F” on their label and test report, to clearly indicate that a less stringent leak test criteria has been applied.

7.5.2.2 Test specimen

For leak testing, a filter element is required which can be sealed into the test rig and subjected to an air flow direction in accordance with the final requirements.

7.5.2.3 Test apparatus

The arrangement of the individual components of the test apparatus for the scan test is shown in [Figure 3](#). The pre-filtered test air is drawn in by a fan and passed through a secondary filter (see [7.2](#)). The air volume flow rate is measured by a standardised air volume flow measuring device in accordance with ISO 5167-1, or any other volume flow rate measuring device which can be calibrated, and shall be kept constant by a flow rate controller. A neutralised aerosol with a mean size corresponding to the MPPS of the filter medium and at the nominal face velocity of the filter element is introduced and distributed uniformly upstream of the filter. One or more mechanically movable sample probes are provided downstream to permit traversing the entire face.

Upstream and downstream particle count measurements are made with OPC's or DMPS (see ISO 29463-2) with or without dilution.

7.5.2.4 Measurement procedure

Leak testing is performed at the nominal air flow rate of the filter. The test aerosol is introduced uniformly upstream of the filter. The downstream concentration is sampled by the sampling probes which traverse the entire (100 %) face of the filter in overlapping scan tracks and at a defined linear rate of movement. The particle concentration is compared with that upstream side and the local penetration at each location of the traversing probe determined. In the scanning operation, the entire surface of the filter element shall be covered in overlapping tracks.

7.5.2.5 Evaluation of test results

Using the test parameters of the leak test (see ISO 29463-4), the permissible local value of the efficiency (see [Tables 1](#) and [2](#)) and taking statistical relationships into account (see ISO 29463-2), it is possible to calculate a limit value for the particle counting rate that indicates a leak.

If the limit value for the particle counting rate is not exceeded at any point on the filter surface, the filter has passed the leakage test and considered to be leak free.

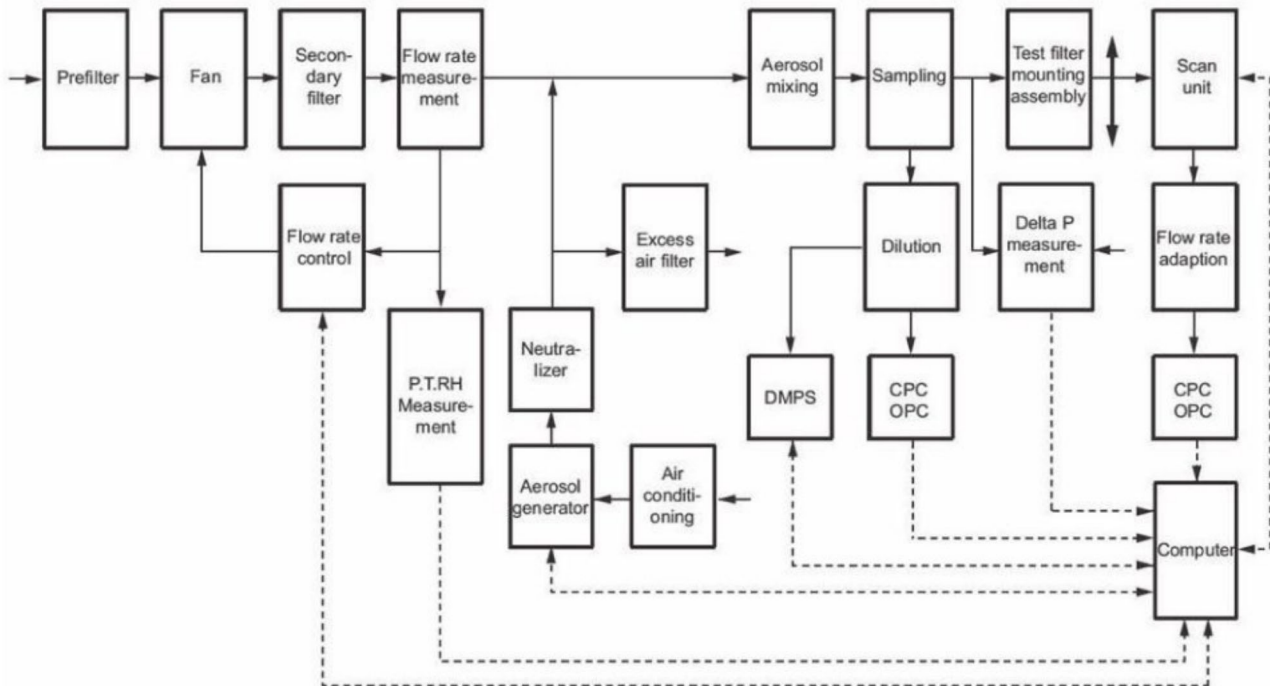

Figure 3 — Arrangement of apparatus for leak testing

7.5.3 Test method for determining the efficiency of filter elements

7.5.3.1 General

The overall efficiency of the complete filter element is determined by measuring the average particle concentration on the upstream and downstream sides of the filter with stationary sampling probes. For all filter classes, measurements are made with discrete particles and particle counters. For Group H filters, as noted above, other test methods that may be used by agreement between supplier and customer are noted in ISO 29463-5:2011, Annexes A, B and C.

7.5.3.2 Test specimen

The test specimen used shall be tested for leakage and be leak-free in accordance with 7.5.2.

7.5.3.3 Test apparatus

The test to determine the overall efficiency of the filter element shall be carried out in a test apparatus shown in Figure 4. The upstream portion of the system used in the efficiency test setup is schematically similar to the test apparatus used for the leakage test, and is discussed further in ISO 29463-5. The test filter mounting assembly is followed by a flow channel, which mixes the aerosol on the downstream side uniformly over the whole cross section of the channel. A stationary sample port is provided downstream of the filter for particle measurement. The air is discharged through an exhaust filter.

The test procedure is described in detail in ISO 29463-5. The individual methods of measurement are described in ISO 29463-2.

7.5.3.4 Measurement procedure

The filter element shall be subjected to the nominal air volume flow rate with the same aerosol as used for the leak test. The particle concentration shall be measured on the upstream and downstream side of the filter element being tested. A dilution circuit is included on the upstream side to adjust the concentration to that measurable by the particle counters (see ISO 29463-2). The pressure differential across the filter element is measured, before the filter is subject to test aerosol.

7.5.3.5 Evaluation of test results

The overall efficiency shall be calculated from the particle concentrations measured on the upstream and downstream side of the filter element being tested (see ISO 29463-2 and ISO 29463-5).

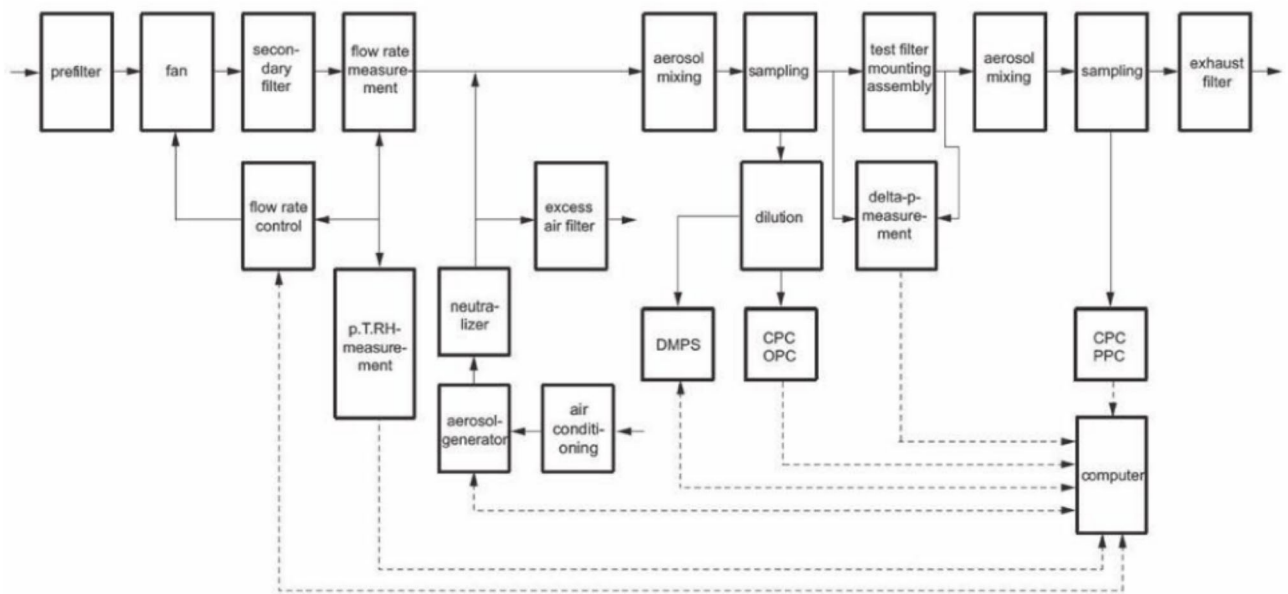

Figure 4 — Arrangement of apparatus for efficiency testing using the static measuring method

7.5.4 Remarks

On the basis of the value(s) determined for overall efficiency, and for filters of groups H and U for local efficiency (absence of relevant leaks), filter elements shall be assigned to a filter class as specified in 6.5. This classification is only valid if the fixed test conditions and procedures are met.

In all three procedural steps given in 7.5.1, 7.5.2 and 7.5.3, it is permissible to use either a monodisperse or a polydisperse test aerosol. The particle counting method used may be a total count method (CPC) or a method involving particle size analysis (OPC).

Since total count particle counting methods provide no information about the particle size, they may only be used to determine the efficiency in 7.5.1 with monodisperse test aerosols of a known particle size.

For the determination of the minimum efficiency of the flat sheet filter medium (7.5.1), the test method using a monodisperse test aerosol has to be considered as the reference test method. Care has to be taken for the correlation with the reference test method if using a polydisperse aerosol for the steps in 7.5.2 and 7.5.3.

For production testing, filter manufacturers may use data of their filter medium supplier, instead of doing these test themselves, as long as the data is fully traceable and documented and the tests are done in full accordance with ISO 29463 (all parts) and, in particular, with ISO 29463-3.

However, it is necessary to be aware that in any case, it remains the responsibility of the filter manufacturer to ensure the correctness in accordance with this document, traceability and

documentation of the data. This can be accomplished by maintaining a quality management system, e.g. ISO 9000, including supplier audits and regular cross checking of the data provided by the filter medium supplier or verified by third party measurements. The cross checking of the filter medium data shall be done using an accepted statistical method, which can be the skip lot procedure as described in ISO 2859-1 or any equivalent alternative method.

8 Assessment of the filter, documentation, test reports

The EPA, HEPA or ULPA filter tested fully in accordance with this document shall be assigned to a filter class in accordance with [Tables 1](#) and [2](#) on the basis of its overall efficiency (penetration) as determined in accordance with [7.5.3](#), and for filters of Groups H and U, the requirements for its local efficiency, that is, absence of relevant leaks, determined in accordance with [7.5.2](#).

The test results shall be documented in a test certificate or test report. The test report shall give full information about the tested object (filter medium or filter), test parameters, e.g. air flow volume, test method, aerosol and particle or aerosol sampling instrumentation (particle counters) used, and the test results.

Detailed requirements for test reports depend on the type of test conducted and can be found in

- ISO 29463-3:2011, Clause 11 for filter medium testing,
- ISO 29463-4:2011, Clause 9 for filter element leak testing, and
- ISO 29463-5:2011, Clause 10 for filter element efficiency testing.

Test reports for the filter medium, in accordance with ISO 29463-3, are meant for internal use and shall form part of the Quality Assurance documentation of a company. Test reports for the filter element of filters of Groups H and U shall be part of the documentation that is normally supplied together with such filters. On the test reports for Group H and U filters, it is recommended to combine the information required in ISO 29463-4 and in ISO 29463-5 and issue a combined test report with all required information.

9 Marking

9.1 The filter shall be marked with the following type identification details:

- a) name, trade mark or other means of identification of the manufacturer;
- b) model, serial number and date of manufacture of the filter;
- c) a reference to this document, i.e. ISO 29463-1;
- d) class of the filter (see [Tables 1](#) and [2](#)), including marking if another normative method in ISO 29463-4 is used for leak scanning;
- e) nominal air volume flow rate at which the filter has been classified;
- f) differential pressure sampled value at which the filter has been classified.
- g) date of testing

9.2 Marking of airflow direction through the filter shall be recorded to indicate proper installation orientation (e.g. with "TOP", "Direction of flow" or an arrow symbol).

9.3 The marking shall be as clearly visible and as durable as possible.

Annex A (informative)

Filtration of nanoparticles

Nano-aerosols are made of particles having one or more dimensions of the order of 100 nm or less. There is a lot of interest around nanoparticles because, at the nanoscale, their physical properties are quite different than the bulk material from which they are made of. However, currently there are concerns about man-made nanoparticles escaping into the environment, both indoors and outdoors, causing adverse health effects. There are some safety issues that are currently not fully understood and assessed.

Since the cleanliness of indoor environments is usually ensured by filtration systems, nanoparticle filtration is a key topic in the development of filtration test standards and their applications. The theory of particle capture by fibrous filters resulted in the now commonly known penetration curve with its distinct most penetrating particle size (MPPS). The efficiency of the filter is at its minimum, or its penetration at its maximum, for the MPPS and better at all other particle sizes, both larger and smaller than the MPPS. For typical current glass fibre media of Group H and U filters, the MPPS is between 120 nm and 250 nm. It has been speculated that the theory of particle capture could fail for nanoparticles, i.e. the penetration at these particle sizes will increase instead of decrease as the particle size decreases. Current research by Pui, et al^{[6][7][8]} shows that the penetration curve is valid for particles down to 5 nm. The research illustrates that testing and classifying filters at or near its MPPS will continue to yield the worst case performance, and safest classification, even down to nanoparticle. Hence, the procedures and classification schemes prescribed in ISO 29463 (all parts) is valid for filters used for nanoparticles. These filters result in a filter performance better than at their MPPS at which they are evaluated and classified. Thus, it is believed that Group H and U filters classified according to ISO 29463 (all parts) result in filters with efficiencies for removing nanoparticles equal to or better than the ones measured for MPPS particles in accordance with ISO 29463 (all parts).

It should be noted that, while the filters discussed in ISO 29463 (all parts) show higher efficiencies for nanoparticle filtration, actual efficiency of a filter for a specific nano-size particle is dependent on the particle measurement device and not on the procedures prescribed in ISO 29463 (all parts). Current measurement devices and methods capable of detecting nanoparticles are more common in research than in commercial measurements, mostly due to economics. Discussions of these devices and their merits are outside the scope of ISO 29463 (all parts).

Annex B (informative)

Summary of classification and test methods

[Table B.1](#) provides detailed information about the permissible test methods in accordance with ISO 29463 (all parts) for each filter group and class of filters.

Table B.1 — Overview of classification and test methods

Filter Class (number) Filter Group (letter)	Limit for overall value ^a		Limit for local value ^{a,b}		Test procedures							
	Efficiency (%)	Penetration (%)	Efficiency (%)	Penetration (%)	Overall efficiency test					Local efficiency test = Leak test ^b		
ISO 15 E	≥95	≤5	—	—	X ^c							
ISO 20 E	≥99	≤1	—	—	X ^c							
ISO 25 E	≥99,5	≤0,5	—	—	X ^c							
ISO 30 E	≥99,90	≤0,1	—	—	X ^c							
ISO 35 H	≥99,95	≤0,05	≥99,75	≤0,25	X ^d	X	X	X	X	X ^e	X	
ISO 40 H	≥99,99	≤0,01	≥99,95	≤0,05	X ^d	X	X	X	X	X ^e		
ISO 45 H	≥99,995	≤0,005	≥99,975	≤0,025	X ^d	X	X	X	X	X ^e		
ISO 50 U	≥99,999	≤0,001	≥99,995	≤0,005	X ^d	X				X ^e		
ISO 55 U	≥99,999 5	≤0,000 5	≥99,997 5	≤0,002 5	X ^d	X				X ^e		
ISO 60 U	≥99,999 9	≤0,000 1	≥99,999 5	≤0,000 5	X ^d	X				X ^e		
ISO 65 U	≥99,999 95	≤0,000 05	≥99,999 75	≤0,000 25	X ^d	X				X ^e		
ISO 70 U	≥99,999 99	≤0,000 01	≥99,999 9	≤0,000 1	X ^d	X				X ^e		
ISO 75 U	≥99,999 995	≤0,000 005	≥99,999 9	≤0,000 1	X ^d	X				X ^e		
^a See also Tables 1 and 2 . ^b Local penetration values lower than those given in Tables 1 and 2 may be agreed upon between the supplier and customer. ^c Statistical efficiency test method may be applied per ISO 29463-5:2011, 4.2. ^d Efficiency test of each individual filter applies per ISO 29463-5:2011, Clause 8. ^e Comment in the test protocol and classification shall be made that filter is tested per ISO 29463-4:2011, Annex E.					ISO 29463-4, Test with movable probe	ISO 29463-5, Test with static probe	ISO 29463-4, Annex C	ISO 29463-4, Oil tread leak test	ISO 29463-4, Photometer scan test	ISO 29463-4, PSL leak test	ISO 29463-4, 0.3 μm leak test	ISO 29463-4, Photometer overall test

Bibliography

- [1] ISO 2859-1, *Sampling procedures for inspection by attributes — Part 1: Sampling schemes indexed by acceptance quality limit (AQL) for lot-by-lot inspection*
- [2] ISO 5167-1, *Measurement of fluid flow by means of pressure differential devices inserted in circular cross-section conduits running full — Part 1: General principles and requirements*
- [3] ISO 9000, *Quality management systems — Fundamentals and vocabulary*
- [4] ISO 14644-3, *Cleanrooms and associated controlled environments — Part 3: Test methods*
- [5] ISO 29464:2011, *Cleaning equipment for air and other gases — Terminology*
- [6] KIM S.C., HARRINGTON M., PUI D.Y.H. Experimental Study of Nanoparticle Penetration through Commercial Filter Media. *J. Nanopart. Res.* 2007, **9** pp. 117–125
- [7] WANG J., CHEN D.R., PUI D.Y.H. Modelling of Filtration Efficiency of Nanoparticles in Standard Filter Media. *J. Nanopart. Res.* 2007, **9** pp. 109–115
- [8] JAPUNTICH D.A., FRANKLIN L.M., PUI D.Y.H., KUEHN T.H., KIM S.C., VINER A.S. A Comparison of two nano-sized particle air filtration tests in the diameter range of 10 to 400 nanometers. *J. Nanopart. Res.* 2007, **9** pp. 93–107
- [9] EN 1822-1:2009, *High efficiency air filters (HEPA and ULPA) - Part 1: Classification, Performance testing and marking*
- [10] EN 1822-2:2009, *High efficiency air filters (HEPA and ULPA) - Part 2: Aerosol production, measuring equipment, particle counting statistics*
- [11] EN 1822-3:2009, *High efficiency air filters (HEPA and ULPA) - Part 3: Testing flat sheet filter media*
- [12] EN 1822-4:2009, *High efficiency air filters (HEPA and ULPA) - Part 4: Determining leakage of filter elements (Scan method)*
- [13] EN 1822-5:2009, *High efficiency air filters (HEPA and ULPA) - Part 5: Determining the efficiency of filter elements*
- [14] IES T RP CC 001. HEPA and ULPA Filters, Institute of Env. Science and Technology, Arlington Heights, IL, USA
- [15] IES T RP CC 007. – Testing ULPA filters, Institute of Env. Science and Technology, Arlington Heights, IL, USA
- [16] IES T RP CC 013 *Calibration Procedures and Guidelines for Select Equipment Used in Testing Cleanrooms and Other Controlled Environments, Institute of Env. Science and Technology, Arlington Heights, IL, USA*
- [17] IES T RP CC 021. –Testing HEPA and ULPA Media, Institute of Env. Science and Technology, Arlington Heights, IL, USA
- [18] IEST RP CC -034. –Leak Testing HEPA and ULPA filters, Institute of Env. Science and Technology, Arlington Heights, IL, USA
- [19] US Military Standard 282, Filter Units, Protective Clothing, Gas-Mask Components And Related Products: Performance-Test Methods

